

Current Transducer HAT 750-S

For the electronic measurement of currents: DC, AC, pulsed,..., with galvanic isolation between the primary circuit (high power) and the secondary circuit (electronic circuit).

$$I_{PN} = 750 \text{ A}$$

$$V_{OUT} = \pm 4 \text{ V}$$



47143

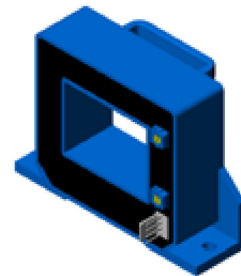

Electrical data

I_{PN}	Primary nominal current rms	750	A
I_{PM}	Primary current, measuring range ¹⁾	± 2250	A
V_C	Supply voltage ($\pm 5\%$) ¹⁾	± 15	V
I_C	Current consumption (max)	± 15	mA
R_{IS}	Isolation resistance @ 500 VDC	> 1000	M Ω
V_{OUT}	Output voltage (Analog) @ $\pm I_{PN}$, $R_L = 10 \text{ k}\Omega$, $T_A = 25^\circ\text{C}$	± 4	V
R_{OUT}	Output internal resistance	100	Ω
R_L	Load resistance	> 10	k Ω

Accuracy - Dynamic performance data

X	Accuracy @ I_{PN} , $T_A = 25^\circ\text{C}$ (excluding offset)	$< \pm 1$	% of I_{PN}
ϵ_L	Linearity error ²⁾ ($0 \dots \pm I_{PN}$)	$< \pm 1$	% of I_{PN}
V_{OE}	Electrical offset voltage @ $T_A = 25^\circ\text{C}$	$< \pm 20$	mV
V_{OH}	Hysteresis offset voltage @ $I_P = 0$, after an excursion of $1 \times I_{PN}$	$< \pm 10$	mV
TCV_{OE}	Temperature coefficient of V_{OE}	$< \pm 1$	mV/K
TCV_{OUT}	Temperature coefficient of V_{OUT} (% of reading)	$< \pm 0.1$	%/K
t_r	Response time to 90 % of I_{PN} step	< 5	μs
BW	Frequency bandwidth (-3 dB) ³⁾	DC .. 25	kHz

General data

T_A	Ambient operating temperature	- 10 .. + 80	$^\circ\text{C}$
T_S	Ambient storage temperature	- 15 .. + 85	$^\circ\text{C}$
m	Mass	300	g

Notes: ¹⁾ Operating at $\pm 12 \text{ V} \leq V_C < \pm 15 \text{ V}$ will reduce the measuring range

²⁾ Linearity data exclude the electrical offset

³⁾ Please refer to derating curves in the technical file to avoid excessive core heating at high frequency.

Features

- Hall effect measuring principle
- Galvanic isolation between primary and secondary circuit
- Low power consumption
- Isolated plastic case recognized according to UL 94-V0.

Advantages

- Easy installation
- Small size and space saving
- Only one design for wide current ratings range
- High immunity to external interference.

Applications

- AC variable speed drives
- DC motor drives
- Battery supplied applications
- Uninterruptible Power Supplies (UPS)
- Switched Mode Power Supplies (SMPS)
- Power supplies for welding applications.

Application domain

- Industrial

Current Transducer HAT 750-S

Isolation characteristics

V_d	Rms voltage for AC isolation test, 50 HZ, 1 min	4.9	kV
\hat{V}_w	Impulse withstand voltage 1.2/50 μ s	> 9.0	kV
		Min	
dCp	Creepage distance	9.9	mm
dCI	Clearance distance	9.9	mm
CTI	Comparative Tracking Index (group IIIa)	275	

Applications examples

According to **EN 50178** and **IEC 61010-1** standards and following conditions:

- Over voltage category III
- Pollution degree PD2
- Non-uniform field

	EN 50178	IEC 61010-1
dCp, dCI, \hat{V}_w	Rated isolation voltage	Nominal voltage
Single isolation	800 V	800 V
Reinforced isolation	400 V	300 V

Safety



This transducer must be used in electric/electronic equipment with respect to applicable standards and safety requirements in accordance with the manufacturer's operating instructions.



Caution, risk of electrical shock

When operating the transducer, certain parts of the module can carry hazardous voltage (eg. primary busbar, power supply).

Ignoring this warning can lead to injury and/or cause serious damage.

This transducer is a build-in device, whose conducting parts must be inaccessible after installation.

A protective housing or additional shield could be used.

Main supply must be able to be disconnected.

Dimensions HAT 750-S (in mm. 1 mm = 0.0394 inch)

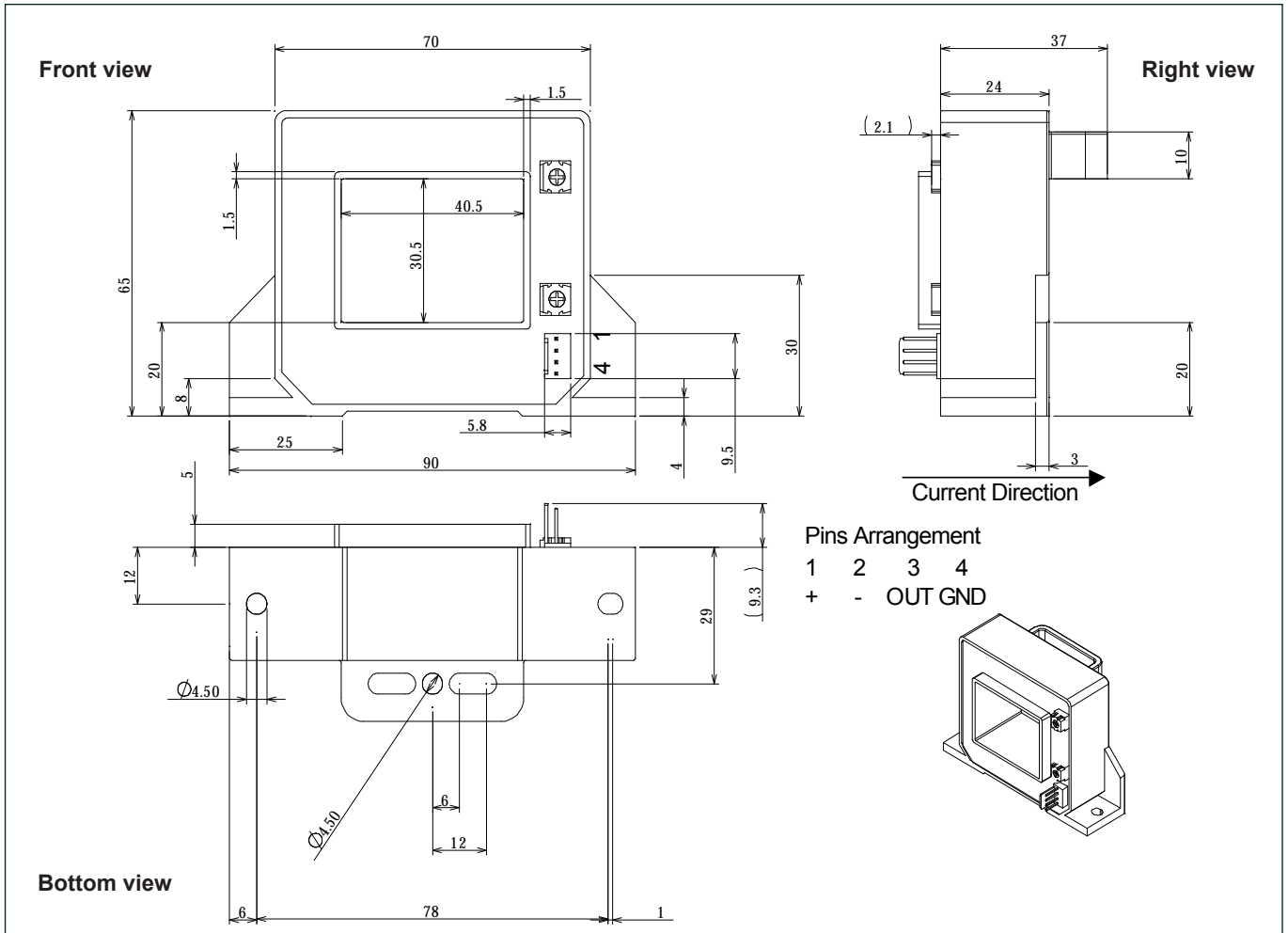

Mechanical characteristics

- General tolerance ± 1 mm
- Transducer fastening By base-plate or on busbar with M4 screws
All slots $\varnothing 4.5$ mm
- Recommended fastening torque 0.75Nm $\pm 20\%$ (0.6~0.9Nm), or 0.55Lb-Ft $\pm 20\%$ (0.44~0.66Lb-Ft)
- Connection of secondary Molex 5045-04A

Remarks

- I_s is positive when I_p flows in the direction of the arrow.
- The temperature of the primary busbar cannot exceed 100°C.